

ESPLOSO E LISTA RICAMBI SPARE PARTS LIST

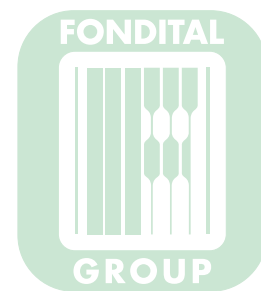

NIAS CONDENSING LINE TECH KB 24-28



LIBRA CONDENSING LINE TECH KB 24-28

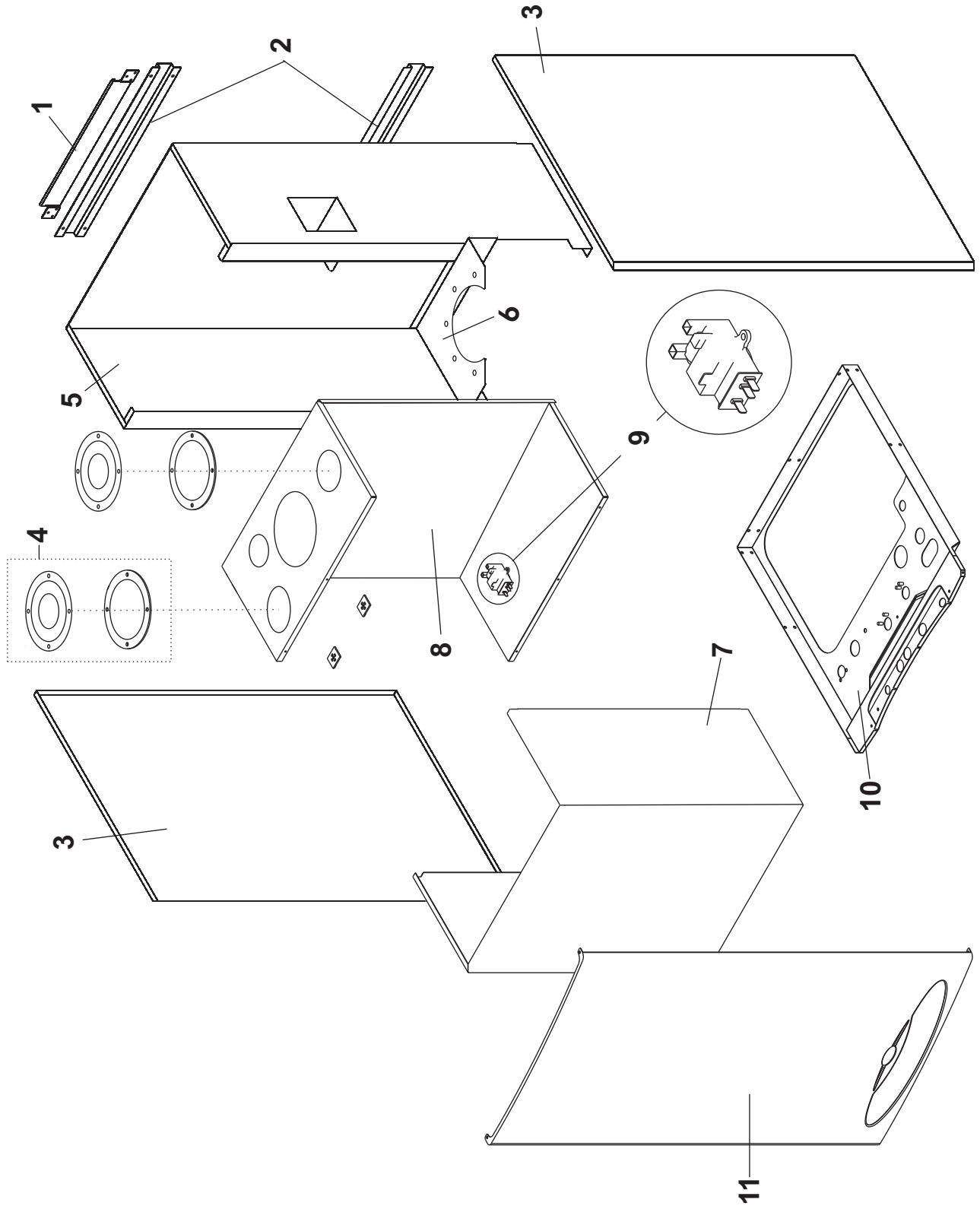

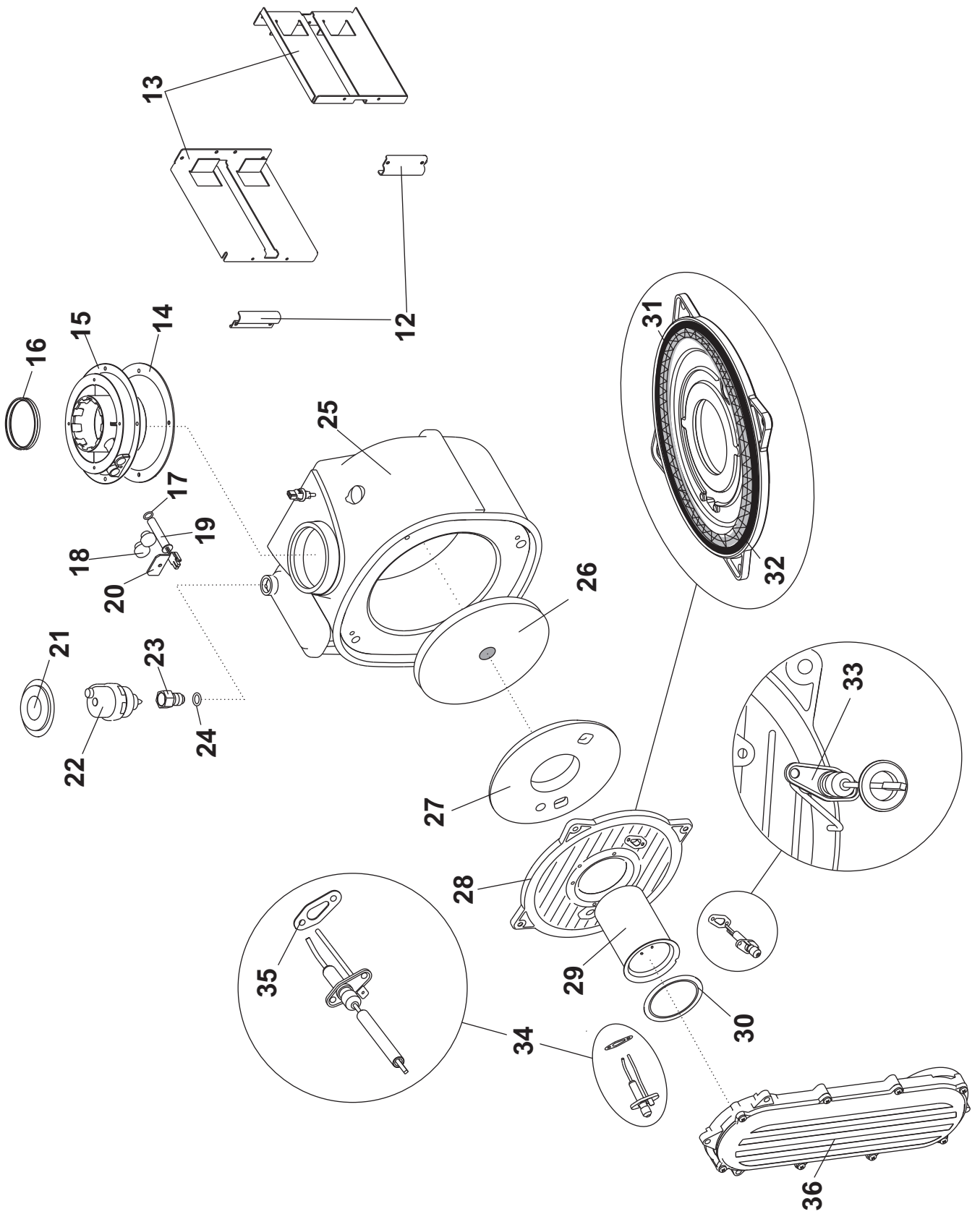

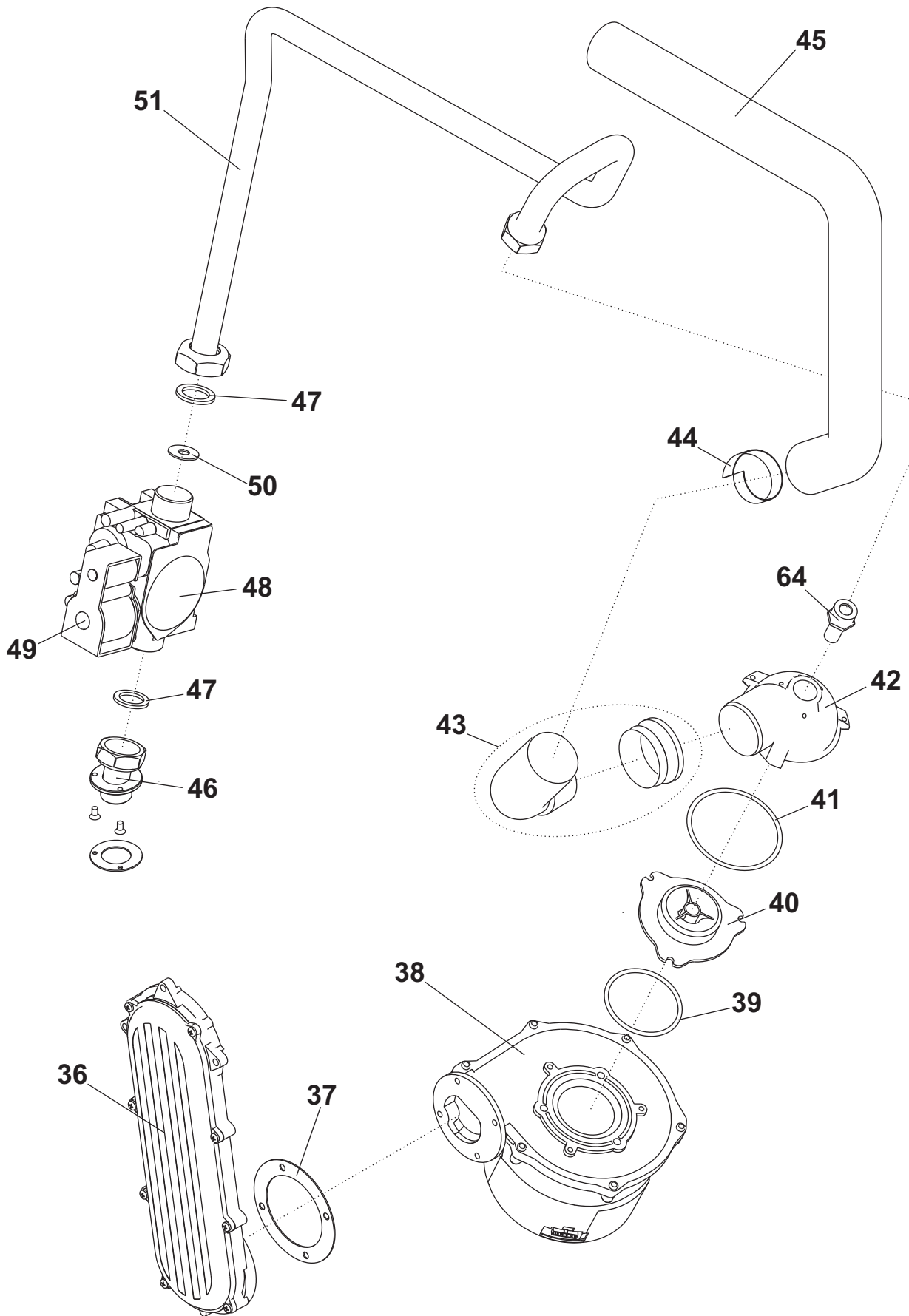

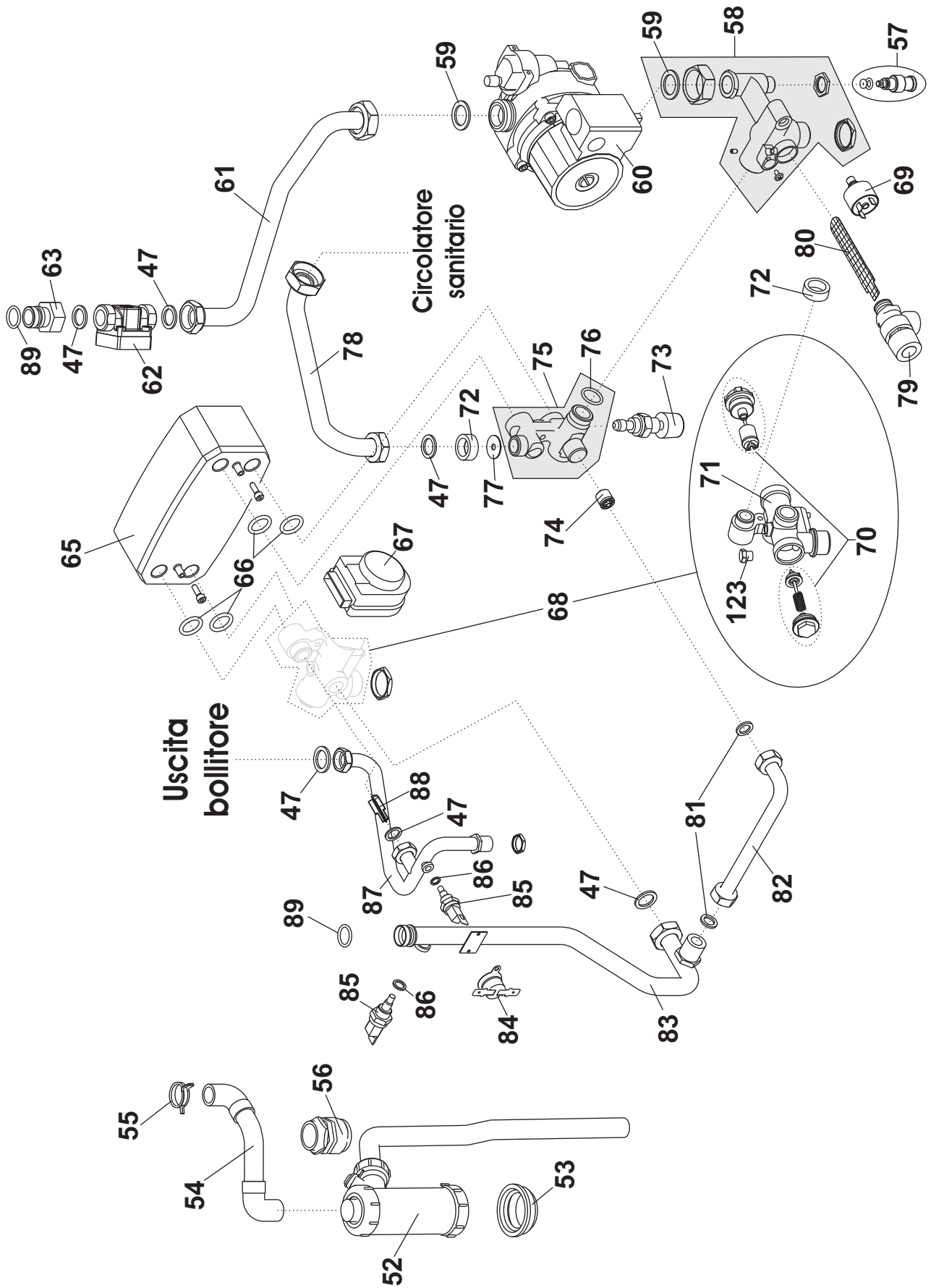

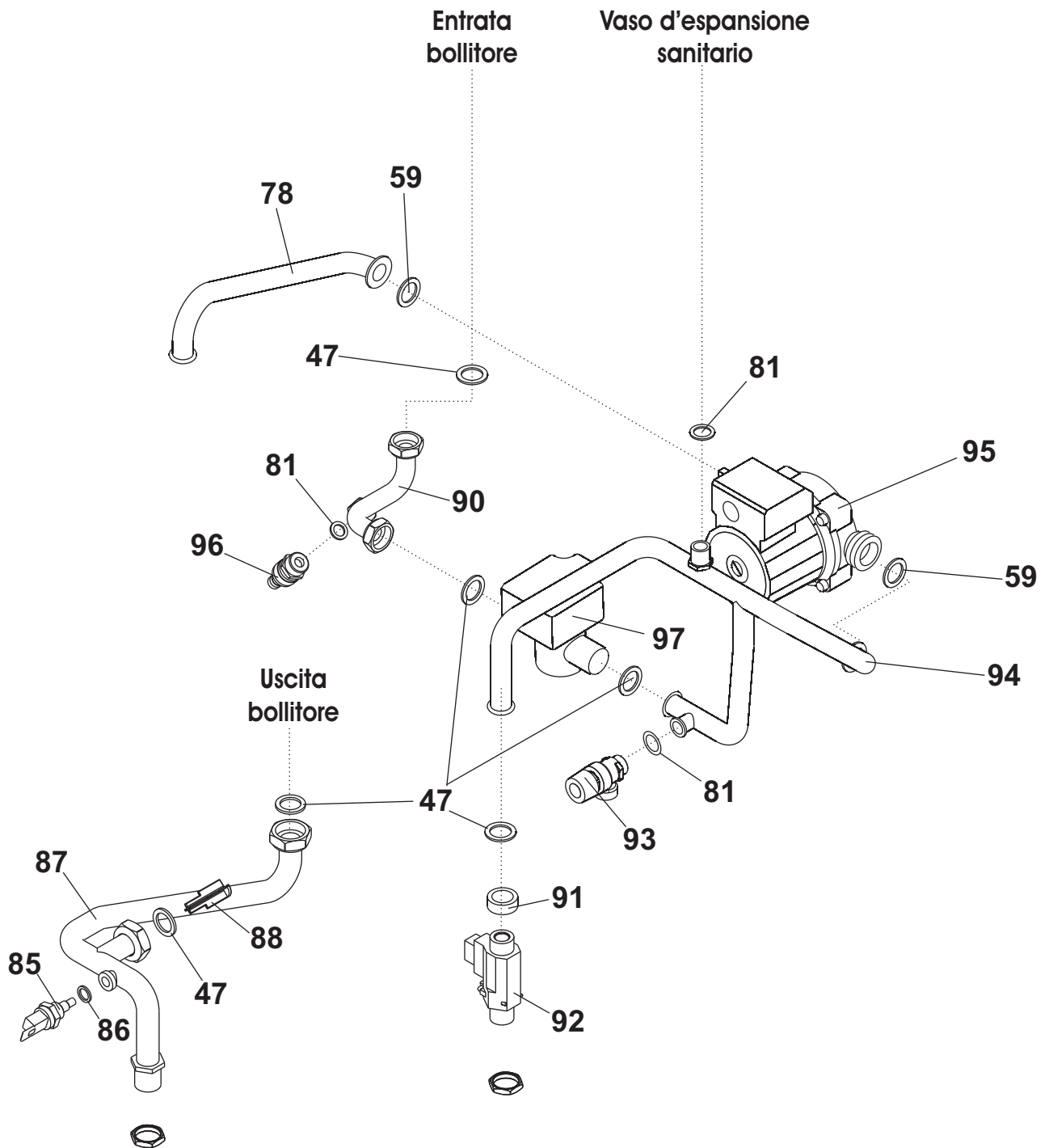

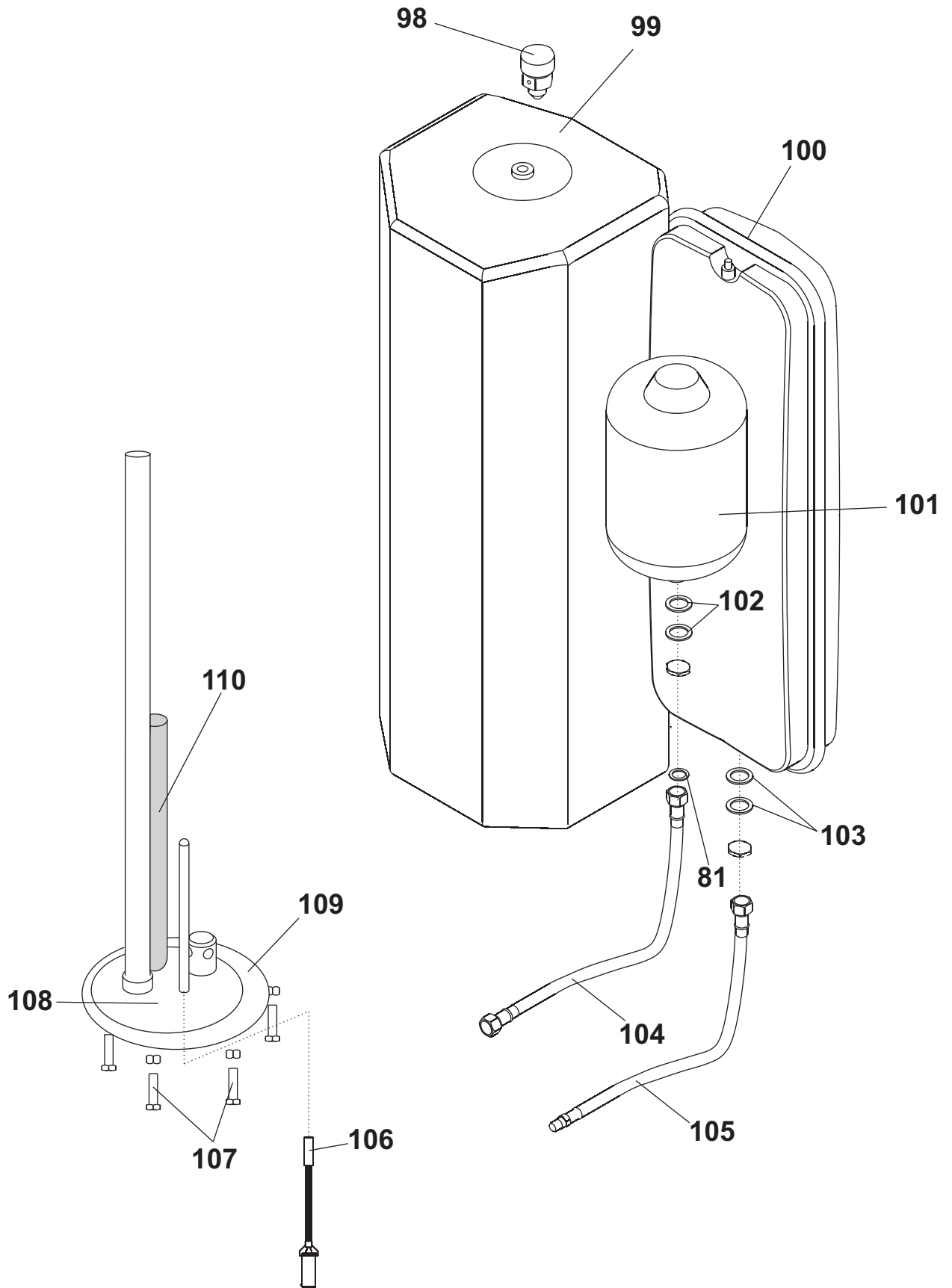

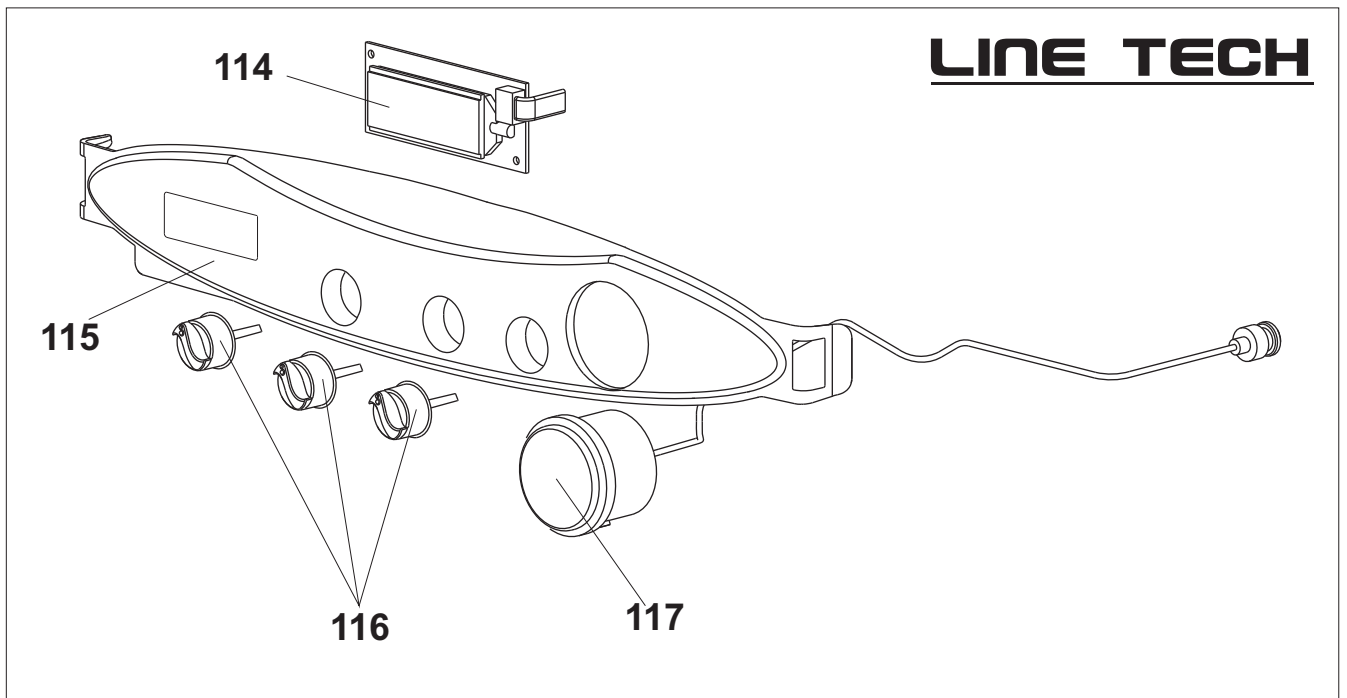
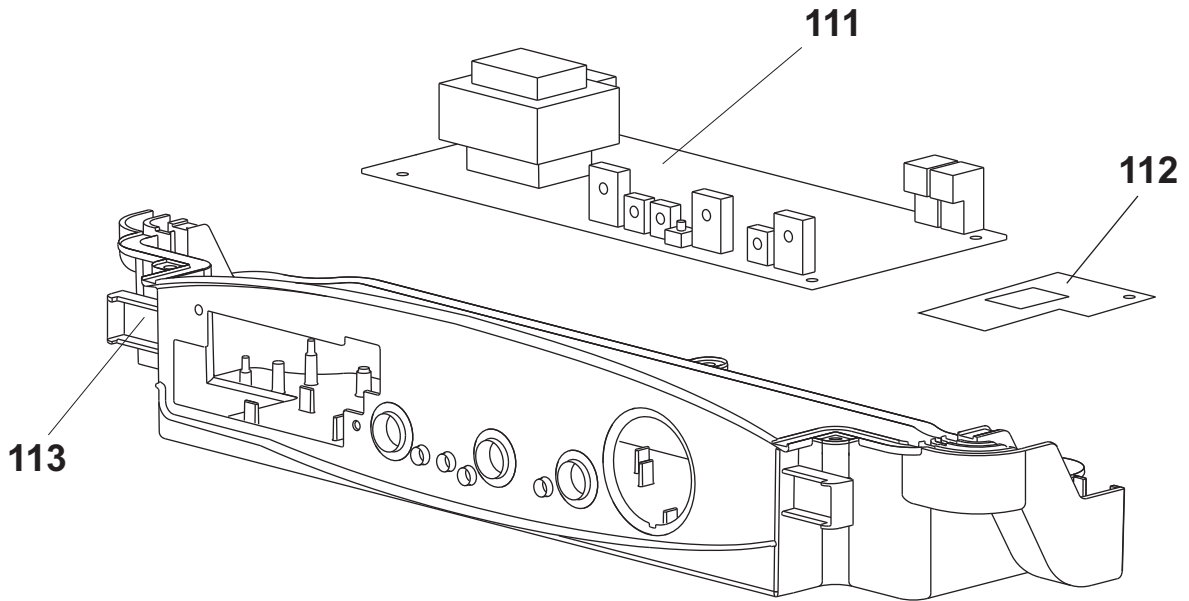
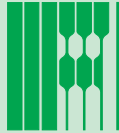

NIAS - LIBRA CONDENSING LINE TECH KB 24-28

Esp	Codice/Code	Pz/Pcs	Descrizione	Description
1	6STASOST04	1	STAFFA DI AGGANCIO PER SOSTEGNO A MURO	HOOKING WALL BRACKET
2	6PROFPOR00	2	PROFILO PORTANTE CALDAIA	BOILER SUPPORTING PROFILE
3	6PANLACM01	1	PANNELLO LATERALE	SIDE PANEL
4	6COPTACF01	1	TAPPO CHIUSURA FUMI	FLUE GASES PLUG
5	6STRUPOR00	1	STRUTTURA PORTANTE CALDAIA	BOILER SUPPORTING STRUCTURE
6	6PIASFIS01	1	PIASTRA FISSAGGIO BOLLITORE	TANK HEATER CLAMP
7	6FRONCAM01	1	PANNELLO FRONTALE CASSA ARIA CONDENSAZIONE	SEALED CHAMBER'S FRONT PANEL
8	6POSTCAM02	1	PANNELLO POSTERIORE CASSA ARIA COND.	SEALED CHAMBER'S REAR PANEL
9	6YTRAACC00	1	TRASFORMAT. D'ACCENSIONE CON FILTRO	IGNITION TRANSFORMER
10	6FONDMUR11	1	FONDELLO CALDAIA CON ACCUMULO 07	BASE
11	6PANFRM05	1	PANNELLO FRONTALE LINE NF SENZA FORO VISORE	DUAL LINE LINE NF FRONT PANEL WITHOUT INSPECTION HOLE
	6PANFRM06	1	PANNELLO FRONTALE LINE FN SENZA FORO VISORE	DUAL LINE LINE FN FRONT PANEL WITHOUT INSPECTION HOLE
12	6PIAFISC00	1	PIASTRINA DI FISSAGGIO SCAMBIATORE	HEAT EXCHANGER FIXING PLATE
13	6STAFISC02	1	STAFFA SCAMBIATORE 24 KW	HEAT EXCHANGER 24 kw CLAMP
	6STAFISC03	1	STAFFA SCAMBIATORE 28 KW	HEAT EXCHANGER 28 kw CLAMP
14	6GUARNIZ35	1	GUARNIZIONE PER TORRETTA DI SCARICO	FLUE GAS DISCHARGE TOWER SEAL
15	6TORRSCA00	1	TORRETTA DI SCARICO	FLUE GAS DISCHARGE TOWER
16	6GUARNIZ37	1	GUARNIZ TRIPLO LABBRO	TRIPPLE LIPPED SEAL
17	6ORTERFU00	10	O-RING PER TERMOSTATO FUMI	O-RING FOR THERMOSTAT
18	6WTAPFUM02	5	TAPPO DI CHIUSURA FORO D.12 MM	D.12 MM CLOSING CAP
19	6INSETER00	1	INSERTO PER TERMOSTATO FUMI	INSERT FOR THERMOSTAT
20	6PIASCHIO0	1	PIASTRINA CHIUSURA TORRETTA SCARICO	SEALING PLATE FOR FLUE GAS DISCHARGE TOWER
21	6WGUASIL03	5	GUARNIZIONE PER VALVOLA DI SFIATO	RELIEF VALVE GAS
22	6VALSFAU01	1	VALVOLA SFIATO G3/8	AUTOMATIC RELIEF VALVE
23	6ADATSFIO0	1	ADATTATORE PER VALVOLA DI SFIATO	AIR VALVE ADAPTER
24	6ORADSFIO0	10	O-RING PER ADATTATORE VALVOLA SFIATO	O-RING FOR AIR VALVE ADAPTER
25	6SCAMCON00	1	SCAMBIATORE CONDENSAZIONE 24 kw	HEAT EXCHANGER CONDENSING 24 kw
	6SCAMCON02	1	SCAMBIATORE CONDENSAZIONE 28 kw	HEAT EXCHANGER CONDENSING 28 kw
26	6ISOLSET00	1	ISOLAMENTO SETTO DIVISORIO SCAMBIATORE COND.	ISOLATION FOR EXCHANGER SEPARATOR
27	6ISOLBRU00	1	ISOLANTE PORTABRUCIATORE	BURNER HOLDER INSULATION
28	6PORTBRU00	1	PORTA BRUCIATORE	HEAT EXCHANGER DOOR
29	6BRUMMET06	1	BRUCIATORE CONDENSAZIONE 24 kw	CONDENSING BURNER 24 kw
	6BRUMMET07	1	BRUCIATORE CONDENSAZIONE 28 kw	CONDENSING BURNER 28 kw
30	6GUARBRU00	3	GUARNIZIONE BRUCIATORE	HEAT EXCHANGER GASKET
31	6GUARPOR00	1	GUARNIZIONE IN SILICONE	SILICONE LIP GASKET
32	6TRECPO00	1	TRECCIA PER PORTABRUCIATORE SCAMBIATORE COND.	GLASS BRAID HIGH TEMPERATURE
33	6CANDRIL00	3	CANDELA RILEVAZIONE	DETECTION PLUG
34	6CANDACC00	3	CANDELA ACCENSIONE	IGNITER PLUG
35	6GUARNIZ38	5	GUARNIZIONE PER ELETTRODI	GASKET FOR PLUG
36	6MANARGA00	1	MANICHETTA ARIA/GAS	AIR/GAS SLEEVE
37	6GUARVEN01	1	GUARNIZIONE VENTILATORE	VENTILATOR GASKET
38	6VENTILA11	1	VENTILATORE	VENTILATOR
39	6ORVENCA01	10	O-RING VENTILATORE	VENTILATORE O-RING
40	6MISCASP00	1	MISCELATORE D'ASPIRAZIONE 24 kw	AIR MIXING DEVICE FOR 24 kw

41	6GUARNIZ40	1	GUARNIZIONE PER CALOTTA D'ASPIRAZIONE	AIR INTAKE CAP SEAL
42	6CALOASP00	1	CALOTTA D'ASPIRAZIONE	AIR INTAKE CAP
43	6CURVTEC02	1	CURVA TECNICA 50 mm +GUARNIZIONE	50mm TECHNICAL CURVE WITH GASKET
44	6Y41160000	1	GUARNIZIONE IN GRAFITE	GRAPHITE GASKET
45	6TUBOCOR03	1	TUBO CORRUGATO D 40mm	D 40mm WRINKLED TUBE
46	6CURFIVG00	1	CURVETTA DI FISSAGGIO X VALVOLA SIT	ELBOW FOR SIT GAS VALVE
47	6GROMNIA03	10	GUARNIZIONE 3/4"	3/4" GASKET
48	6VALVGAS05	1	VALVOLA GAS PER CONDENSAZIONE	CONDENSING GAS VALVE
49	6YBOBINA00	1	BOBINA VALVOLA GAS SIT 840-845-848	840-845-848 SIT GAS VALVE COIL
50	6DIAFRAM23	3	DIAFRAMMA Ø7,2 COND. 24-28kw G20	G20 24-28 kw COND. BOILER Ø7,2 DIAPHRAGM
	6DIAFRAM25	3	DIAFRAMMA Ø5,3 COND. 24-28kw G31	G31 24-28 kw COND. BOILER Ø5,3 DIAPHRAGM
51	6TUBOGAS27	1	TUBO GAS COLL.VENTILATORE 24 kw	CONNECTION VENTILATOR GAS TUBE (24 kw)
	6TUBOGAS28	1	TUBO GAS COLL.VENTILATORE 28 kw	CONNECTION VENTILATOR GAS TUBE (28 kw)
52	6SIFRACO01	1	SIFONE RACCOGLI CONDENSA CON TAPPO PIATTO	CONDENSATE TRAP WITH FLAT CAP
53	6MANICOT05	1	MANICOTTO D.60	JOINT
54	6TUSCACO01	1	TUBO SCARICO CONDENSA DOPPIA CURVA	CONDENSATE DRAIN PIPE DOUBLE CURVE
55	6FASCMOL01	1	FASCETTA A MOLLA	SPRING RETAINER
56	6PRESCAV01	1	PRESSACAVO	CABLE GLAND
57	6RUBISCA01	1	CORPO RUBINETTO DI SCARICO PER CALDAIA	BOILER DRAIN COCK UNIT
58	6GRIDRIR00	1	GRUPPO IDRAULICO RICAMBIO DI RITORNO RISC.	HYDRAULIC UNIT FOR HEATING RETURN CIRCUIT
59	6GROMNIA04	10	GUAR. 1" OMNIA TESNIT BA-U 30X21X2	GASKET 1" OMNIA TESNIT BA-U 30X21X2
60	6CIRCOLA07	1	CIRCOLATORE RSL 15/6-3-KU-CLR-3 (24-28 KW)	CIRCULATING PUMP RSL 15/6-3-KU-CLR-3 (24-28 KW)
61	6TUBRIIM12	1	TUBO RITORNO IMPIANTO RISCALDAMENTO (ACCUMULO)	RETURN DUCT FROM THE HEATING SYSTEM
62	6BASFLUS01	1	FLUSSOSTATO RISCALDAMENTO	HEATING SYSTEM FLOW CONTROL
63	6ADATFLU00	1	ADATTATORE PER FLUSSOSTATO	FLOW SWITCH ADAPTER
64	6TERTUGA00	1	TERMINALE PER TUBO GAS	TERMINAL FOR GAS TUBE
65	6SCAMPIA06	1	SCAMBIATORE 26 PIASTRE (24-28 kw)	26-PLATE HEAT EXCHANGER (24-28 kw)
66	6ORSCAPI00	10	O-RING DI TENUTA SU SCAMBIATORE A PIASTRE	PLATE HEAT EXCHANGER O-RING SEAL
67	6PROATT00	1	PROGRAMMATORE ATTUATORE 1651/2.0.00	ACTUATOR PROGRAMMER 1651/2.0.00
68	6CORPVAL02	1	VALVOLA A TRE VIE COMPLETA CONDESAZIONE	CONDENSING 3 WAY VALVE UNIT
69	6PRESSAC00	1	PREOSSOSTATO ACQUA	WATER PRESSURE SWITCH
70	6OTTUPIA00	1	OTTURATORE RISCALDAMENTO E PIATTELLO SANITARIO	CH SHUTTER AND DHW PLATE
71	6CORTREV01	1	CORPO VALVOLA A TRE VIE SENZA BY-PASS	3 WAY VALVE BODY WITHOUT BYPASS
72	6RIDUZIO04	1	RIDUZIONE G3/4 M-G1/2 F	ADAPTER G3/4 M-G1/2 F
73	6RUBICAR04	1	RUBINETTO DI RIEMPIMENTO KRAMER L=50	KRAMER L=50 FILLING TAP
74	6VALVBYP01	1	VALVOLA BY-PASS	BY-PASS VALVE
75	6RACSCAM03	1	CORPO RACCORDO X SCAMBIATORE A PIASTRE	PLATE HEAT EXCHANGER BODY
76	6ORRASCP00	10	O-RING DI TENUTA SU RACCORDO PER SCAMBIATORE	HEAT EXCHANGER O-RING SEAL
77	6DIAFRAM33	5	DIAFRAMMA CALDAIA MURALE 24KW 6,4MM	DIAPHRAGM 24KW 6,4 MM
	6DIAFRAM34	5	DIAFRAMMA CALDAIA MURALE 28KW 6.6MM	DIAPHRAGM 28KW 6.6 MM
78	6TUBACFR04	1	TUBO ACQUA FREDDA POMPA-SCAMBIATORE	CIRC. PUMP-HEAT EXCHANGER COLD WATER TUBE
79	6VALSIBA07	1	VALVOLA SICUREZZA 3 BAR INNESTO RAPIDO	3 BAR SNAP-ON SAFETY VALVE
80	6FILTRIT00	3	FILTRO PER RITORNO IMPIANTO RISCALDAMENTO	RETURN FILTER CH
81	6GROMNIA02	10	GUAR.1/2"OMNIA TESNIT BA-U18.5X11X2	GASKET 1/2" OMNIA TESNIT BA-U 18,5X11X2
82	6TUBOBYP00	1	TUBO PER BY-PASS	BY-PASS TUBE
83	6TUBMAIM18	1	TUBO DI MANDATA CONDENSAZIONE ACCUMOLO	CONDENSING DELIVERY PIPE
84	6YTERSIC00	3	TERMOSTATO DI SICUREZZA 105 °C	SAFETY THERMOSTAT 105 °C

85	6SONDNTC01	3	SONDA NTC AD IMMERSIONE DUAL LINE	NTC IMMERSION PROBE
86	6WRONDAL00	10	RONDELLA IN ALLUMINIO PER UGELLO	ALUMINIUM WASHER FOR NOZZLE
87	6TUBUSCS05	1	TUBO USCITA ACQUA CALDA SANITARIA	DHW FLOW PIPE
88	6TURBOLA01	1	TURBOLATORE ACQUA SANITARIA	COLD WATER SANITARIE FLUE TURBULENCE ENHANCER
89	6ORTUBCO00	10	O-RING PER TUBI RISCALDAMENTO	O-RING FOR HEATING SYSTEM TUBES
90	6TUBACFR06	1	TUBO ACQUA FREDDA BOLLITORE	BOILER COLD WATER TUBE
91	6RIDUZIO06	1	RIDUZIONE G1/2"F G3/4"M	ADAPTER G1/2"F G3/4"M
92	6FLUSSOS00	1	FLUSSOSTATO BITRON	"BITRON" FLOW CONTROL
93	6VALSIBA08	1	VALVOLA SICUREZZA 6BAR 1/2"	6 BAR SAFETY VALVE 1/2"
94	6TUBACFR05	1	TUBO CARICO ACQUA FREDDA SANITARIA	WATER MAIN INLET PIPE
95	6CIRCOLA09	1	CIRCOLATORE ZRS 15-2-1 KU	CIRCULATING PUMP ZRS 15-2-1 KU
96	6RUBISCA04	1	RUBINETTO DI SCARICO 1/2"	DRAIN COCK 1/2"
97	6VALVINT00	1	VALVOLA 2 VIE	2 WAY VALVE
98	6VALVSFI02	5	VALVOLA SFOGO 1/2"	1/2" RELIEF VALVE
99	6BOLLITO09	1	BOLLITORE 25 LITRI	25 LITRES BOILER
100	6VASOESP17	1	VASO D'ESPANSIONE 8 LT 24KW	8 LITRE EXPANSION TANK 24 KW
	6VASOESP15	1	VASO D'ESPANSIONE 10 LT 28 KW	10 LITRE EXPANSION TANK 28 KW
101	6VASOESP16	1	VASO D'ESPANSIONE 2 LT	2 LITRE EXPANSION TANK
102	6GUARNIZ25	10	GUARNIZIONE 33X21X1,5	GASKET 33X21X1,5
103	6GUARNIZ27	10	GUARNIZIONE 27X17X1,5	GASKET 27X17X1,5
104	6TUBFLEX05	1	TUBO FLESSIBILE	HOSE PIPE
105	6TUBFLEX02	1	TUBO FLESSIBILE F 3/8"X M10X1 X 450	HOSE PIPE F 3/8"X M10X1 X 450
106	6SONDNTC02	1	SONDA NTC	NTC IMMERSION PROBE
107	6DADOBOL00	8	DADO ESAGONALE + VITE BOLLITORE	NUT + SCREW
108	6BLOCFLA00	1	BLOCCO FLANGIA BOLLITORE	FLANGE ASSEMBLY
109	6GUARBOL02	1	GUARNIZIONE 8 FORI D.186	GASKET
110	6ANODMGN01	1	ANODO DI MAGNESIO	SACRIFICIAL ANOD (MAGNESIUM)
111	6SCHEMOD19	1	SCHEDA MODULAZIONE CONDENSING LINE TECH	LINE TECH CONDENSING ELECTRONIC BOARD
112	6CIRCSTA08	1	SCHEDA RELE' PER GESTIONE ACQUA PREMIUM	RELAY PCB FOR AQUA PREMIUM MANAGEMENT
113	6SCAELPA00	1	SCATOLA PER ELETTRONICA PANNELLO PORTASTRUMENTI	CONTROL PANEL BOX FOR ELECTRONIC PARTS
114	6SCHELCD00	1	SCHEDA LCD	LCD BOARD
115	6FRONPAN11	1	PANNELLO PORTASTRUMENTI DUAL LINE LINE TECH FN	DUAL LINE LINE TECH INSTRUMENT PANEL FN
	6FRONPAN13	1	PANNELLO PORTASTRUMENTI DUAL LINE LINE TECH NF	DUAL LINE LINE TECH INSTRUMENT PANEL NF
116	6MANOPOL00	3	MANOPOLA D.18 PER CALDAIA MURALE FN	KNOB D 18 FOR FN BOILER INSTRUMENT PANELS
	6MANOPOL01	3	MANOPOLA D.18 PER CALDAIA MURALE NF	KNOB D 18 FOR NF BOILER INSTRUMENT PANELS
117	6MANOMET01	1	MANOMETRO	PRESSURE GAUGE
118	6CABLCON07	1	CABLAGGIO VENTILATORE - MVD -POMPA - V.GAS	VENTILATOR - MVD -PUMP - V.GAS CONNECTION
119	6CABLCON08	1	CABLAGGIO SONDE-TERMOSTATI-FLUSSOSTATI- PS-2WV	PROBE-THERMOSTAT-FLOWS CONTROLS CONNECTION
120	6CAVOALI00	1	CAVO DI ALIMENTAZIONE	SUPPLY CABLE
121	6CABLCON15	1	CABLAGGIO COLL. FLUSSOSTATO PRESSOSTATO	PRESSURE AND FLOW CONTROL CONNECTION
122	6CABLMUR25	1	CABLAGGIO COLLEGAMENTO SCHEDE	ELECTRONIC BOARD CONNECTION
123	6TAPPOGF04	1	tappo g 1/8" maschio.	plug 1/8" m

